

# CITY OF EDGEWOOD

## **PUBLIC RIGHT-OF-WAY ENCROACHMENT PREREQUISITES & REGULATIONS**

---

**When applying for an Encroachment Permit, the following must be provided in accordance with City Ordinance 2016-07-08:**

- A completed application form.
- Site Plan for proposed work.
- If a private contractor is doing work in the City's rights-of-ways the contractor is required to provide an indemnification letter, proof of Worker's Compensation Insurance, specific to the State of Kentucky and proof of General Liability Insurance.
- A non-refundable application fee of \$100 for the first application in a calendar year and \$15 for each application in the same calendar year.
- Notify the city when work is complete.

**When applying for an Encroachment Permit, the applicant shall follow the subsequent requirements:**

1. Applicant will be required to receive an approved permit prior to starting work. Applicant may be required to review sight distance minimums prior to approval.
2. Driveway Applicants shall place No. 2 or No. 4 stone on first 50 feet of driveway. Driveway must be wide enough to accommodate workers' vehicles. Vehicles are **not** to be illegally parked in the road or on the shoulder of the road.
3. Erosion control methods shall be used to control run-off.
4. Applicant must maintain proper drainage during construction.
5. Applicant must keep road/street clean during construction of mud, stone or debris.
6. Applicant shall follow the City of Edgewood Standard Details in the implementation of the project. The applicant is encouraged to include pertinent details in their application.

You may apply in person, or by mail, for the Encroachment Permit at the City of Edgewood, 385 Dudley Road, Edgewood, KY 41017, or you may fax the completed Application to 859-331-5912. Office hours are Monday through Friday from 8:00 am – 6:00 pm. Should you have further questions regarding the Encroachment Application process, please contact the Public Works Director at 859-331-8126.

***The regulations for removal and excavation of the pavement, surface and sub-surface rocks and soils and other material from the streets and other public ways in the City of Edgewood are regulated by City Ordinance 2016-07-08.***

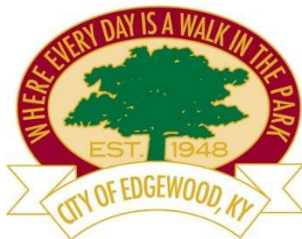

**CERTIFICATE OF ENCROACHMENT APPLICATION  
DRIVEWAY/SIDEWALK  
APPLICATION**

-----*To Be Completed By Applicant*-----

1. Name of Applicant: \_\_\_\_\_  
Mailing Address: \_\_\_\_\_  
\_\_\_\_\_  
City: \_\_\_\_\_  
State: \_\_\_\_\_  
Zip Code: \_\_\_\_\_  
Phone Number: \_\_\_\_\_  
Email Address of Applicant: \_\_\_\_\_

2. Address of Proposed Encroachment: \_\_\_\_\_

3.  N  S  E  W side of (Street): \_\_\_\_\_

Approximately \_\_\_\_\_ Ft.  N  S  E  W of \_\_\_\_\_

4. Is Location of Encroachment on a:  City Road  State Route

5. Duration of Excavation: Start Date:  End Date:

**6. NOTIFY CITY WHEN WORK IS COMPLETE**

7. Purpose of Encroachment: \_\_\_\_\_  
\_\_\_\_\_

8. Additional Information: \_\_\_\_\_  
\_\_\_\_\_  
\_\_\_\_\_  
\_\_\_\_\_

-----*For Official Use Only*-----

Approved:  Yes  No Fee paid: \_\_\_\_\_ (Amt paid)

Conditions: \_\_\_\_\_  
\_\_\_\_\_

Approved By: \_\_\_\_\_ Date: \_\_\_\_\_

Inspected By: \_\_\_\_\_ Date: \_\_\_\_\_

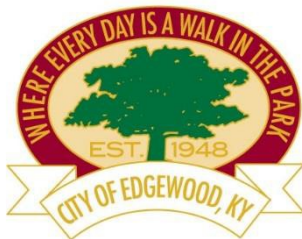

**CERTIFICATE OF ENCROACHMENT APPLICATION  
RIGHTS-OF-WAY EXCAVATION  
ENCROACHMENT APPLICATION**

-----To Be Completed By Applicant-----

1. Name of Applicant: \_\_\_\_\_  
Contact Name: \_\_\_\_\_  
Mailing Address: \_\_\_\_\_  
\_\_\_\_\_  
City: \_\_\_\_\_  
State: \_\_\_\_\_  
Zip Code: \_\_\_\_\_  
Phone Number: \_\_\_\_\_  
Email Address: \_\_\_\_\_

2. Limits of Proposed Encroachment:  
(Attach plan for clarity) \_\_\_\_\_

3. Is Location of Encroachment on a:  City Road  State Route  
Additional Information: \_\_\_\_\_

4. Duration of Excavation: Start Date:  End Date:

5. **NOTIFY CITY WHEN WORK IS COMPLETE**

Additional Information:

6. (Provide list or copies of anticipated City of Edgewood Standard Drawings to be used on this project)  
\_\_\_\_\_  
\_\_\_\_\_  
\_\_\_\_\_  
\_\_\_\_\_

-----For Official Use Only-----

Approved:  Yes  No Fee paid: \_\_\_\_\_ (Amt paid)

Conditions: \_\_\_\_\_  
\_\_\_\_\_

Approved By: \_\_\_\_\_ Date: \_\_\_\_\_

Inspected By: \_\_\_\_\_ Date: \_\_\_\_\_

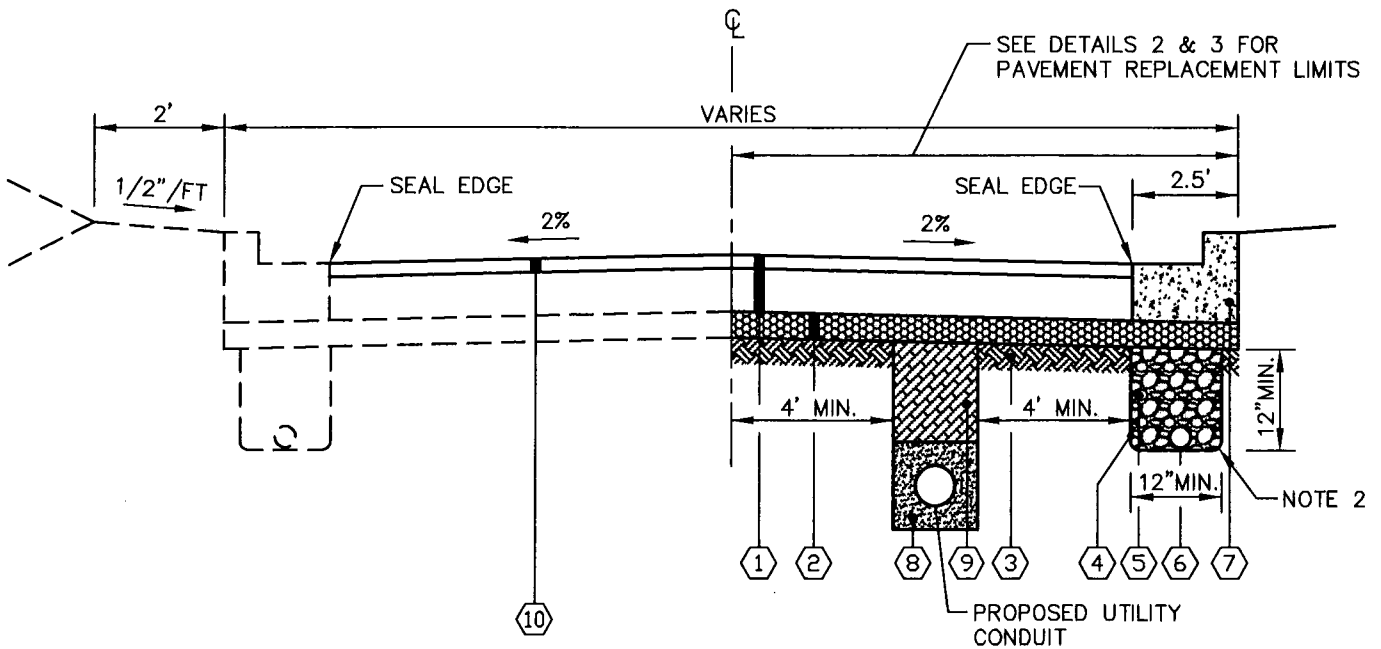

LEGEND:

- ① KTC ITEM 403/402 - ASPHALT PAVEMENT (7" ASPHALT BASE + 2" ASPHALT SURFACE).
- ② KTC ITEM 302 - 4" CRUSHED STONE BASE, COMPACTED TO 100% (ASTM D696) (OMIT IF NO STONE BASE)
- ③ KTC ITEM 207 - SUBGRADE RESHAPED AND COMPACTION OF EXISTING CLAY SUBGRADE.
- ④ KTC ITEM SPL - MIRAFI 140N OR EQUIVALENT NONWOVEN GEOTEXTILE, COVERING DRAINAGE BACKFILL, LAPPED 12" INCHES ONTO CLAY EACH SIDE AND 4" INCHES ONTO BACK OF CURB WHERE APPLICABLE.
- ⑤ KTC ITEM 302 - CLEAN NO. 57 CRUSHED STONE (LESS THEN 3% FINES), COMPACTED IN 6" TO 8" LIFTS TO 80% DENSITY (ASTM D453, D4254) VIA VIBRATORY COMPACTOR (NOTE 2)
- ⑥ KTC ITEM 704 - 4" DIA. RIGID PERFORATED PVC PIPE. (NOTE 2)
- ⑦ KTC ITEM 506 - CONCRETE CURB AND GUTTER. (NOTE 2)
- ⑧ PIPE BEDDING
  - A. COMPACT SAND IN TRENCH IN LAYERS 6" OR LESS TO WIDTH AND ELEVATION SHOWN.
  - B. EXCAVATE A GROOVE IN COMPACTED SAND TO CONFORM TO PIPE SHAPE WITH APPROX. 4" OF SAND BELOW BOTTOM OF PIPE.
  - C. INSTALL PIPE AT CORRECT ALIGNMENT AND ELEVATION RECOMPACT ANY LOOSE SAND DISTURBED DURING INSTALLATION.
- ⑨ BACKFILL - LOW STRENGTH MORTAR BACKFILL
- ⑩ KTC ITEM 403/407 - 2" MILL AND RESURFACE ASPHALT PAVEMENT

NOTE:

- 1.) LIMITS OF RESURFACING SHALL EXTEND 20' BEYOND LIMITS OF UTILITY TRENCH EXCAVATION.
- 2.) ANY EXISTING UNDER DRAIN DISTURBED DURING TRENCHING CONSTRUCTION SHALL BE REPLACED WITH RIGID 4" DIA. PERFORATED PVC PIPE AND/OR CLEAN NO. 57 STONE AS INDICATED ON THE CITY OF EDGEWOOD STREET DETAIL 1.

X:\2016 Projects\16005 Edgewood Eng\Encroachment Permit Drawings\DETAILS.dwg, 6/15/2016 10:43:15 AM, Bluebeam PDF10 Printer, HighRes.pcl

PROJNO DATE  
16005 5-18-16

**City of Edgewood**  
**Encroachment Permit Standard Details**  
 Typical Detail No. 1  
 Typical Pavement Reconstruction  
 For Asphalt Streets





**BRANDSTETTER  
 CARROLL INC**  
 ARCHITECTS-ENGINEERS-PLANNERS  
 308 East 8th Street, Cincinnati, OH 45202  
 p. 513.651.4224 www.brandstettercarroll.com

SHEET

1 OF 1

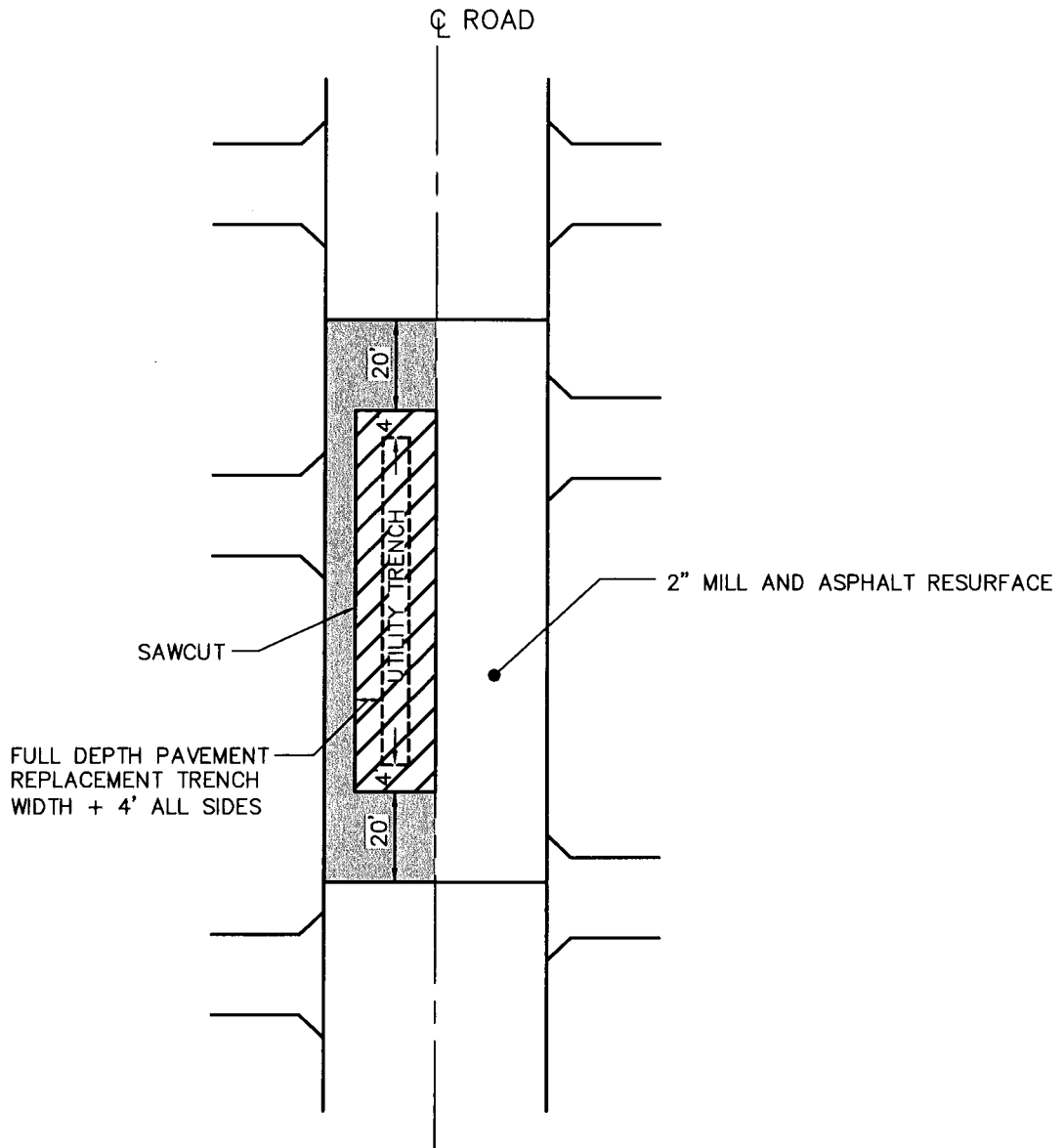
X:\2016 Projects\16005 Edgewood Eng\Encroachment Permit Drawings\DETAILS.dwg, 6/15/2016 10:43:22 AM, Bluebeam PDFIO Printer-HighRes.p3



-  INDICATES LIMITS OF 2" MILL AND ASPHALT RESURFACE
-  PROPOSED PAVEMENT CUT

NOTE:

1. THIS DETAIL REQUIRES THAT THE FULL WIDTH OF A LANE BE MILLED AND PAVED IF WORK OCCURS WITHIN THAT LANE.
2. THIS DETAIL SHALL APPLY ON ALL CITY STREETS, INCLUDING THOSE WITH MULTIPLE LANES.

FOR USE WITH TYPICAL  
DETAIL NO. 1

PROJNO DATE  
16005 5-18-16

**City of Edgewood**  
**Encroachment Permit Standard Details**  
 Typical Detail No. 2  
 Reconstruction Limits  
 For Asphalt Streets





**BRANDSTETTER  
 CARROLL INC**  
 ARCHITECTS • ENGINEERS • PLANNERS  
 308 East 8th Street, Cincinnati, OH 45202  
 p. 513.651.4224 www.brandstettercarroll.com

SHEET

1 OF 1

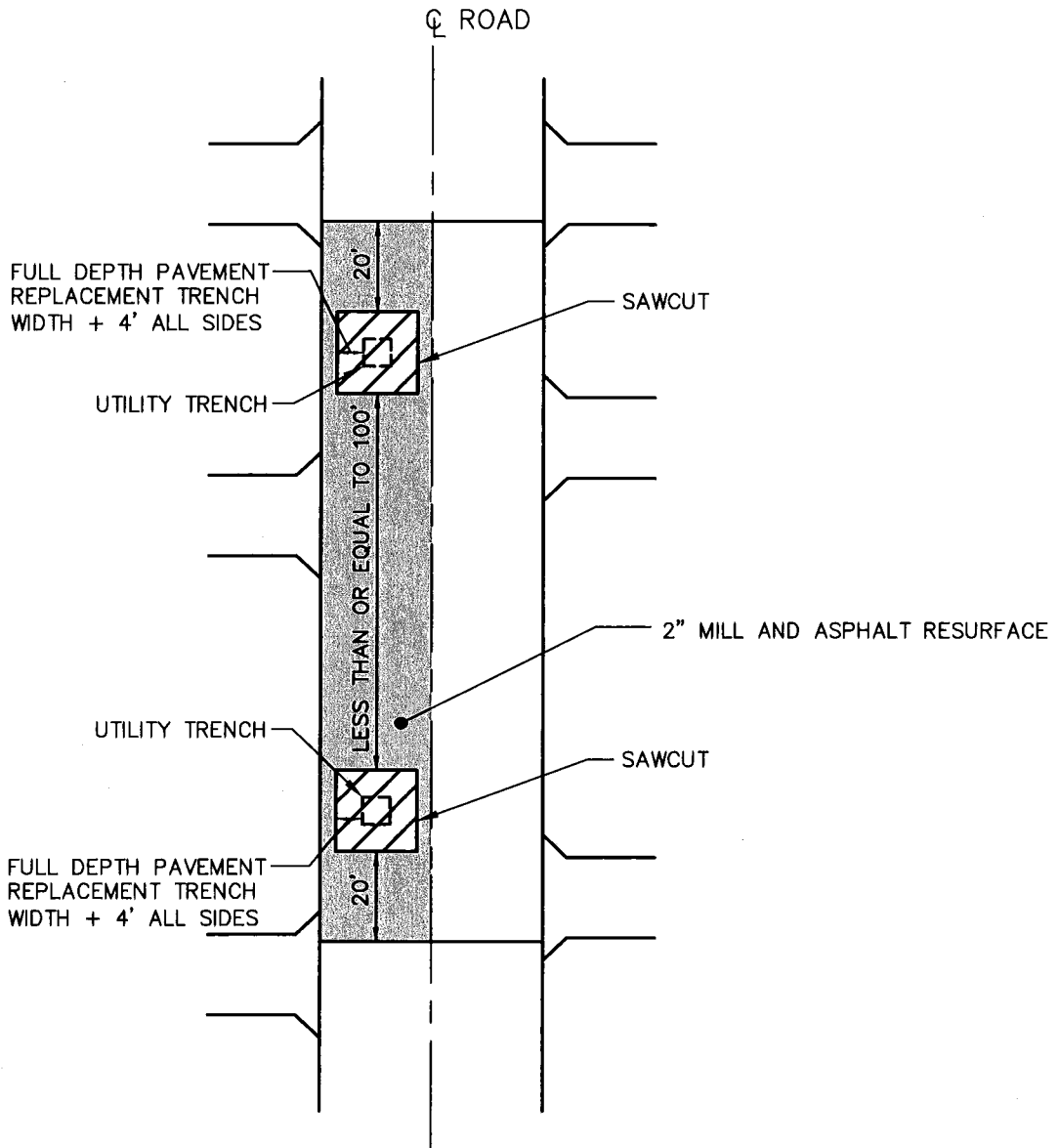
XL\_2016 Projects\16005 Edgewood Eng\Encroachment Permit Drawings\DETAILS.dwg, 6/15/2016 10:43:23 AM, Bluebeam PDFIO Printer-HighRes.p3



-  INDICATES LIMITS OF 2" MILL AND ASPHALT RESURFACE
-  PROPOSED PAVEMENT CUT

NOTE:

1. THIS DETAIL REQUIRES THAT THE FULL WIDTH OF A LANE BE MILLED AND PAVED IF WORK OCCURS WITHIN THAT LANE.
2. THIS DETAIL SHALL APPLY ON ALL CITY STREETS, INCLUDING THOSE WITH MULTIPLE LANES.

FOR USE WITH TYPICAL  
DETAIL NO. 1

PROJNO DATE  
16005 5-18-16

**City of Edgewood**  
**Encroachment Permit Standard Details**  
Typical Detail No. 3  
Reconstruction Limits  
(Several Pavement Cuts On One Street)



**BRANDSTETTER  
CARROLL INC**  
ARCHITECTS • ENGINEERS • PLANNERS  
308 East 8th Street, Cincinnati, OH 45202  
p. 513.631.4224 www.brandstettercarroll.com

SHEET

1 OF 1

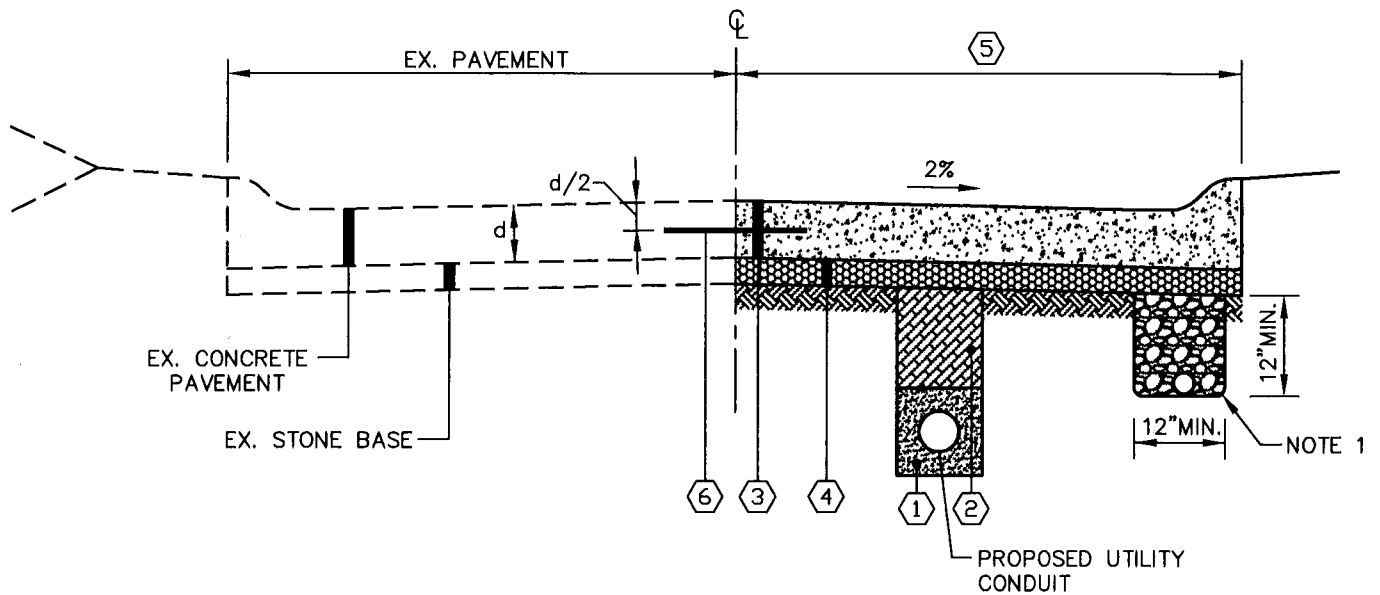

**LEGEND:**

- ① PIPE BEDDING
  - A. COMPACT SAND IN TRENCH IN LAYERS 6" OR LESS TO WIDTH AND ELEVATION SHOWN.
  - B. EXCAVATE A GROOVE IN COMPACTED SAND TO CONFORM TO PIPE SHAPE WITH APPROX. 4" OF SAND BELOW BOTTOM OF PIPE.
  - C. INSTALL PIPE AT CORRECT ALIGNMENT AND ELEVATION RECOMPACT ANY LOOSE SAND DISTURBED DURING INSTALLATION.
- ② BACKFILL
  - A. UNDER ROADWAY PAVEMENT
    - 1. LOW STRENGTH MORTAR BACKFILL
- ③ CONCRETE PAVEMENT REPLACEMENT AS PER KENTON COUNTY SUBDIVISION REGULATIONS.
- ④ DRAINAGE BLANKET
  - A. KTC 302 - 4" CRUSHED STONE BASE, COMPACTED TO 100% (ASTM D696) (OMIT IF NO STONE BASE)
- ⑤ CONCRETE PAVEMENT
  - A. CONCRETE PAVEMENT PER KENTON COUNTY SUBDIVISION REGULATIONS.
    - 1. CONCRETE PAVEMENT SHALL BE SAWCUT, REMOVED, AND REPLACED TO THE NEAREST JOINT. MINIMUM REPAIR = 1 BLOCK = 12'x12'; IF UTILITY TRENCH IS LOCATED WITH IN 2" OF THE CENTER LINE OF THE PAVEMENT, THE ENTIRE PAVEMENT WIDTH SHALL BE REPLACED.
- ⑥ 1/2" REBAR, 18" LONG, 18" O.C. DRILLED INTO EXISTING CONCRETE PAVEMENT (ALL SIDES WHERE NEW CONCRETE ABUTS EX. CONCRETE)

**NOTE:**

- 1.) ANY EXISTING UNDER DRAIN DISTURBED DURING TRENCHING CONSTRUCTION SHALL BE REPLACED WITH RIGID 4" DIA. PERFORATED PVC PIPE AND/OR CLEAN NO. 57 STONE AS INDICATED ON THE CITY OF EDGEWOOD STREET DETAIL 1.

X:\2016 Projects\16005 Edgewood Eng\Encroachment Permit Drawings\DETAILS.dwg, 6/15/2016 10:43:24 AM, Bluebeam PDFIO Printer HighRes.pc3

PROJNO DATE  
16005 5-18-16

**City of Edgewood**  
**Encroachment Permit Standard Details**  
 Typical Detail No. 4  
 Typical Pavement Reconstruction/Restoration  
 For Concrete Streets



**BRANDSTETTER  
 CARROLL INC**  
 ARCHITECTS-ENGINEERS-PLANNERS  
 308 East 8th Street, Cincinnati, OH 45202  
 p. 513.651.4224 www.brandstettercarroll.com

SHEET

1 OF 1

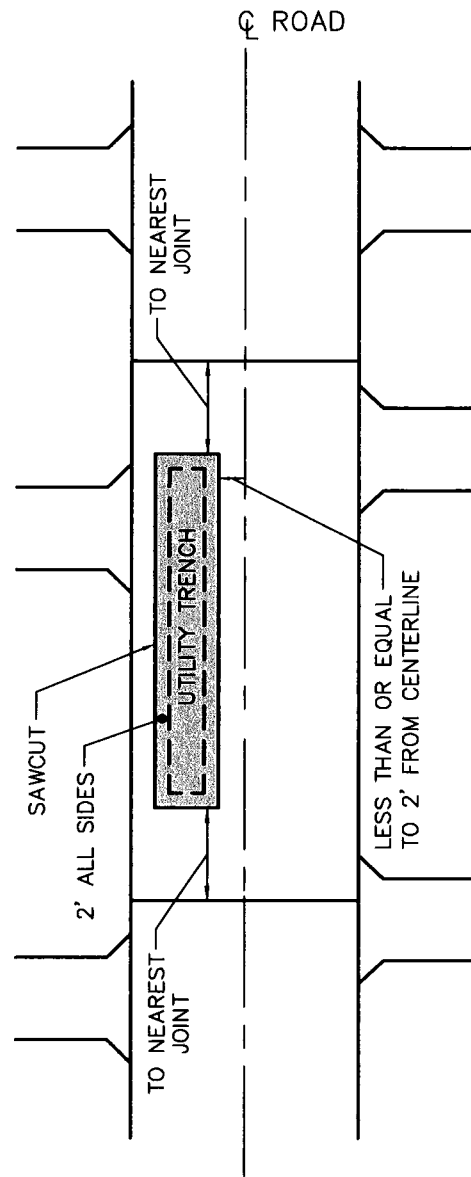
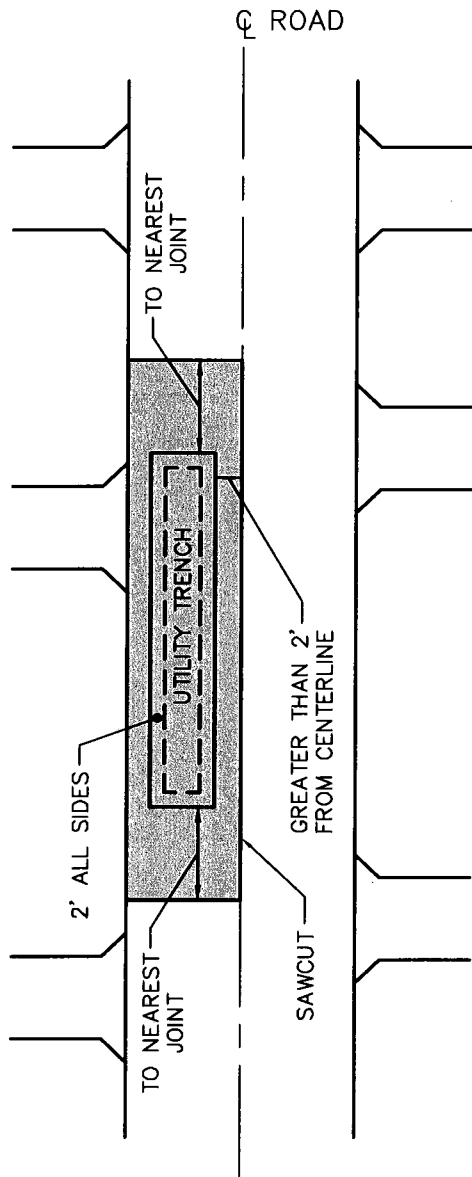

LIMITS OF CONCRETE PAVEMENT REPLACEMENT

\* IF UTILITY TRENCH ENDS WITHIN 2' OF THE NEAREST JOINT, PAVEMENT SHALL BE REPLACED TO THE NEXT JOINT BEYOND THAT.

FOR USE WITH TYPICAL DETAIL NO. 4

PROJNO DATE  
16005 5-18-16

**City of Edgewood**  
**Encroachment Permit Standard Details**  
 Typical Detail No. 5  
 Reconstruction/Restoration Limits  
 For Concrete Streets



**BRANDSTETTER  
 CARROLL INC**  
 ARCHITECTS · ENGINEERS · PLANNERS  
 308 East 8th Street, Cincinnati, OH 45202  
 p. 513.651.4224 www.brandstettercarroll.com

SHEET

1 OF 1



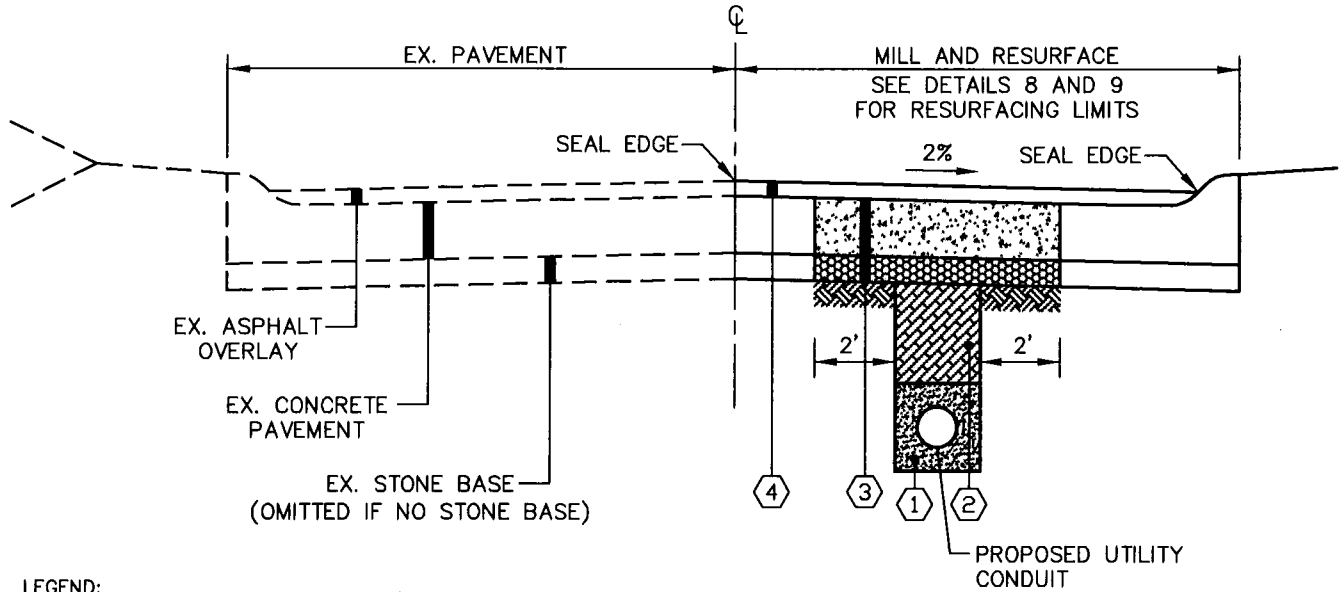

LEGEND:

- ① PIPE BEDDING
  - A. COMPACT SAND IN TRENCH IN LAYERS 6" OR LESS TO WIDTH AND ELEVATION SHOWN.
  - B. EXCAVATE A GROOVE IN COMPACTED SAND TO CONFORM TO PIPE SHAPE WITH APPROX. 4" OF SAND BELOW BOTTOM OF PIPE.
  - C. INSTALL PIPE AT CORRECT ALIGNMENT AND ELEVATION RECOMPACT ANY LOOSE SAND DISTURBED DURING INSTALLATION.
- ② BACKFILL
  - A. UNDER ROADWAY PAVEMENT
    - 1. LOW STRENGTH MORTAR BACKFILL
- ③ PAVEMENT RESTORATION
  - ASPHALT PAVEMENT SHALL BE RESTORED AS PER THE CITY OF EDGEWOOD PAVEMENT RECONSTRUCTION TYPICAL DETAIL NO. 1 (8" NO. 2 CRUSHED LIMESTONE MAY BE OMITTED IF NO STONE BASE EXISTS UNDER THE EXISTING PAVEMENT.)
- ④ MILL EXISTING ASPHALT PAVEMENT AND RESURFACE WITH ASPHALT PAVEMENT. THICKNESS VARIES - MATCH EXISTING

NOTE:

- 1.) ANY EXISTING UNDER DRAIN DISTURBED DURING TRENCHING CONSTRUCTION SHALL BE REPLACED WITH RIGID 4" DIA. PERFORATED PVC PIPE AND/OR CLEAN NO. 57 STONE AS INDICATED ON THE CITY OF EDGEWOOD STREET DETAIL 1.

X:\2016 Projects\16005 Edgewood Eng\Encroachment Permit Drawings\DETAILS.dwg, 6/15/2016 10:43:26 AM, Bluebeam PDF10 Printer-HighRes.pc3

PROJNO DATE  
16005 5-18-16

**City of Edgewood**  
**Encroachment Permit Standard Details**  
**Typical Detail No. 6**  
**Typical Pavement Restoration**  
**For Concrete Street With Asphalt Overlay**



**BRANDSTETTER  
 CARROLL INC**  
 ARCHITECTS-ENGINEERS-PLANNERS  
 308 East 8th Street, Cincinnati, OH 45202  
 p.513.651.4224 www.brandstettercarroll.com

SHEET

1 OF 1

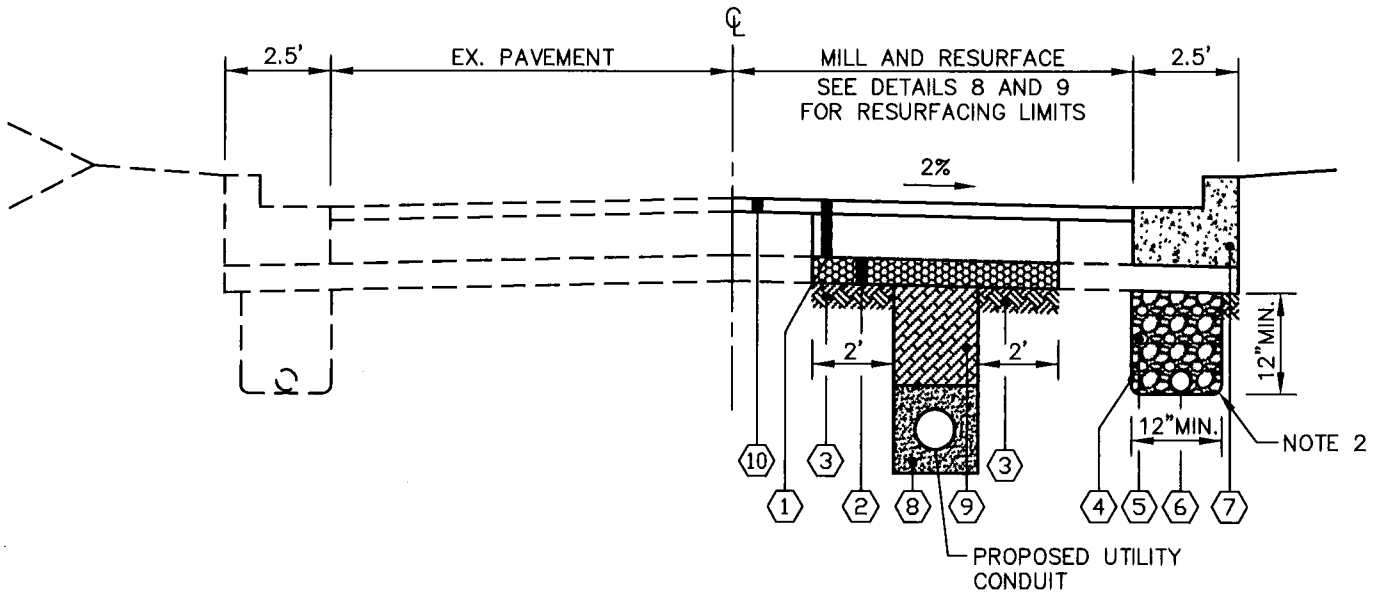

LEGEND:

- ① KTC ITEM 403/402 - ASPHALT PAVEMENT (7" ASPHALT BASE + 2" ASPHALT SURFACE).
- ② KTC ITEM 302 - 4" CRUSHED STONE BASE, COMPACTED TO 100% (ASTM D696) (OMIT IF NO STONE BASE)
- ③ KTC ITEM 207 - SUBGRADE RESHAPED AND COMPACTION OF EXISTING CLAY SUBGRADE.
- ④ KTC ITEM SPL - MIRAFI 140N OR EQUIVALENT NONWOVEN GEOTEXTILE, COVERING DRAINAGE BACKFILL, LAPPED 12" INCHES ONTO CLAY EACH SIDE AND 4" INCHES ONTO BACK OF CURB WHERE APPLICABLE.
- ⑤ KTC ITEM 302 - CLEAN NO. 57 CRUSHED STONE (LESS THEN 3% FINES), COMPACTED IN 6" TO 8" LIFTS TO 80% DENSITY (ASTM D453, D4254) VIA VIBRATORY COMPACTOR (NOTE 2)
- ⑥ KTC ITEM 704 - 4" DIA. RIGID PERFORATED PVC PIPE.
- ⑦ KTC ITEM 506 - CONCRETE CURB AND GUTTER.
- ⑧ PIPE BEDDING
  - A. COMPACT SAND IN TRENCH IN LAYERS 6" OR LESS TO WIDTH AND ELEVATION SHOWN.
  - B. EXCAVATE A GROOVE IN COMPACTED AND TO CONFORM TO PIPE SHAPE WITH APPROX. 4" OF SAND BELOW BOTTOM OF PIPE.
  - C. INSTALL PIPE AT CORRECT ALIGNMENT AND ELEVATION RECOMPACT ANY LOOSE SAND DISTURBED DURING INSTALLATION.
- ⑨ BACKFILL - LOW STRENGTH MORTAR BACKFILL
- ⑩ KTC ITEM 403/407 - 2" MILL AND RESURFACE ASPHALT PAVEMENT

NOTE:

- 1.) LIMITS OF RESURFACING SHALL EXTEND 20' BEYOND LIMITS OF UTILITY TRENCH EXCAVATION.
- 2.) ANY EXISTING UNDER DRAIN DISTURBED DURING TRENCHING CONSTRUCTION SHALL BE REPLACED WITH RIGID 4" DIA. PERFORATED PVC PIPE AND/OR CLEAN NO. 57 STONE AS INDICATED ON THE CITY OF EDGEWOOD STREET DETAIL 1.

X:\2016 Projects\16005 Edgewood Eng\Encroachment Permit Drawings\DETAILS.dwg, 6/15/2016 10:43:27 AM, Bluebeam PDF10 Printer HighRes.pcl

PROJNO DATE  
16005 5-18-16

**City of Edgewood**  
**Encroachment Permit Standard Details**  
 Typical Detail No. 7  
 Typical Pavement Restoration  
 For Asphalt Street





**BRANDSTETTER  
 CARROLL INC**  
 ARCHITECTS-ENGINEERS-PLANNERS  
 308 East 8th Street, Cincinnati, OH 45202  
 p. 513.651.4224 www.brandstettercarroll.com

SHEET

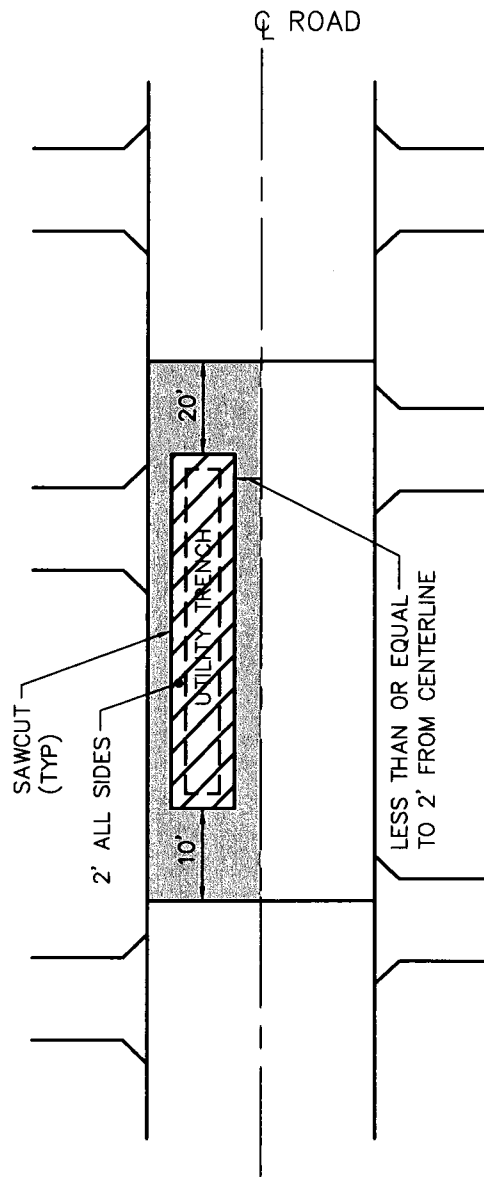
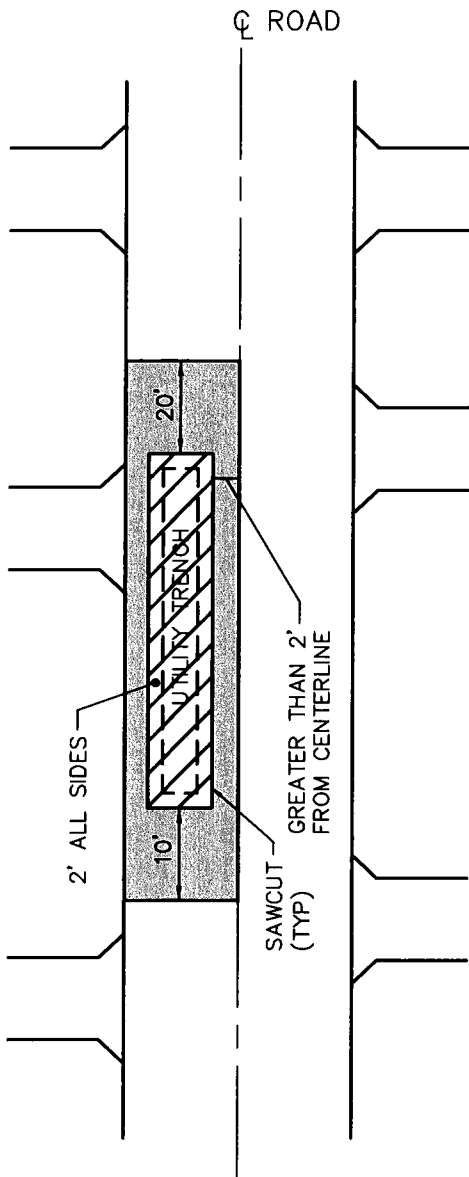
1 OF 1



-  INDICATES LIMITS OF 2" MILL AND ASPHALT RESURFACE
-  PROPOSED PAVEMENT CUT

- NOTE:**
1. THIS DETAIL REQUIRES THAT THE FULL WIDTH OF A LANE BE MILLED AND PAVED IF WORK OCCURS WITHIN THAT LANE.
  2. THIS DETAIL SHALL APPLY ON ALL CITY STREETS, INCLUDING THOSE WITH MULTIPLE LANES.

FOR USE WITH TYPICAL  
DETAIL NO. 6 AND 7

PROJNO DATE  
16005 5-18-16

**City of Edgewood**  
**Encroachment Permit Standard Details**  
**Typical Detail No. 8**  
**Pavement Restoration Limits**  
**(One Pavement Cut On Street)**





**BRANDSTETTER  
CARROLL INC**  
ARCHITECTS • ENGINEERS • PLANNERS  
308 East 8th Street, Cincinnati, OH 45202  
p.513.651.4224 www.brandstettercarroll.com

SHEET

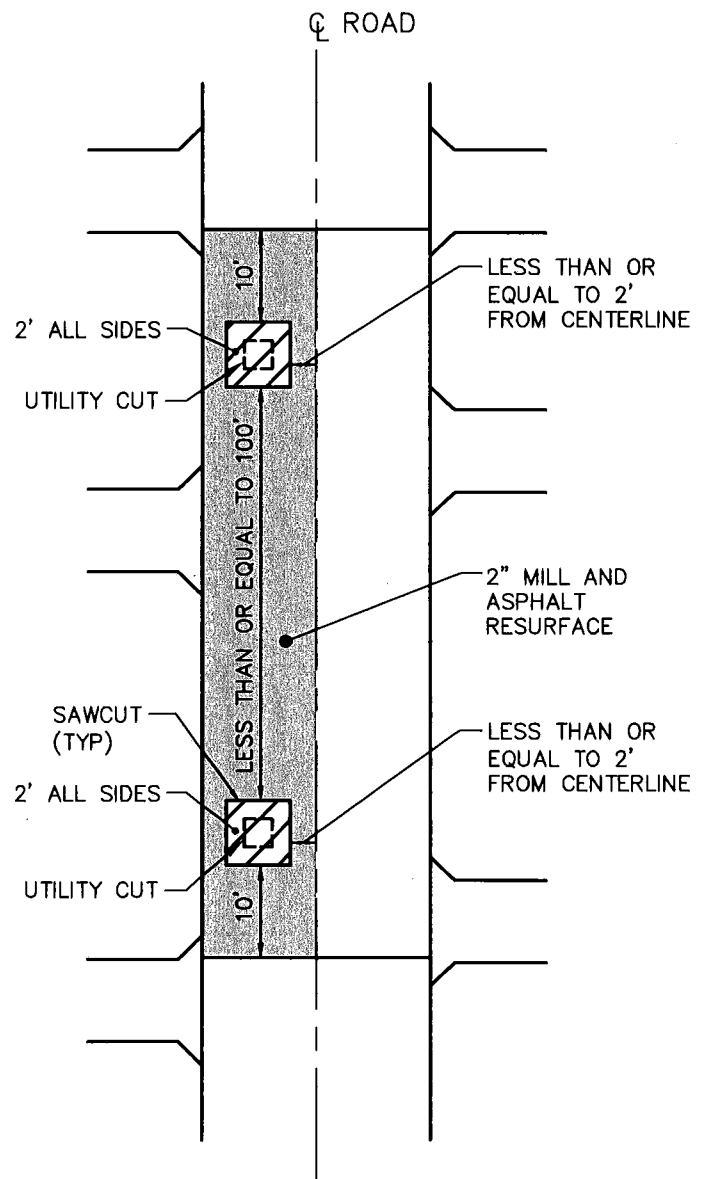
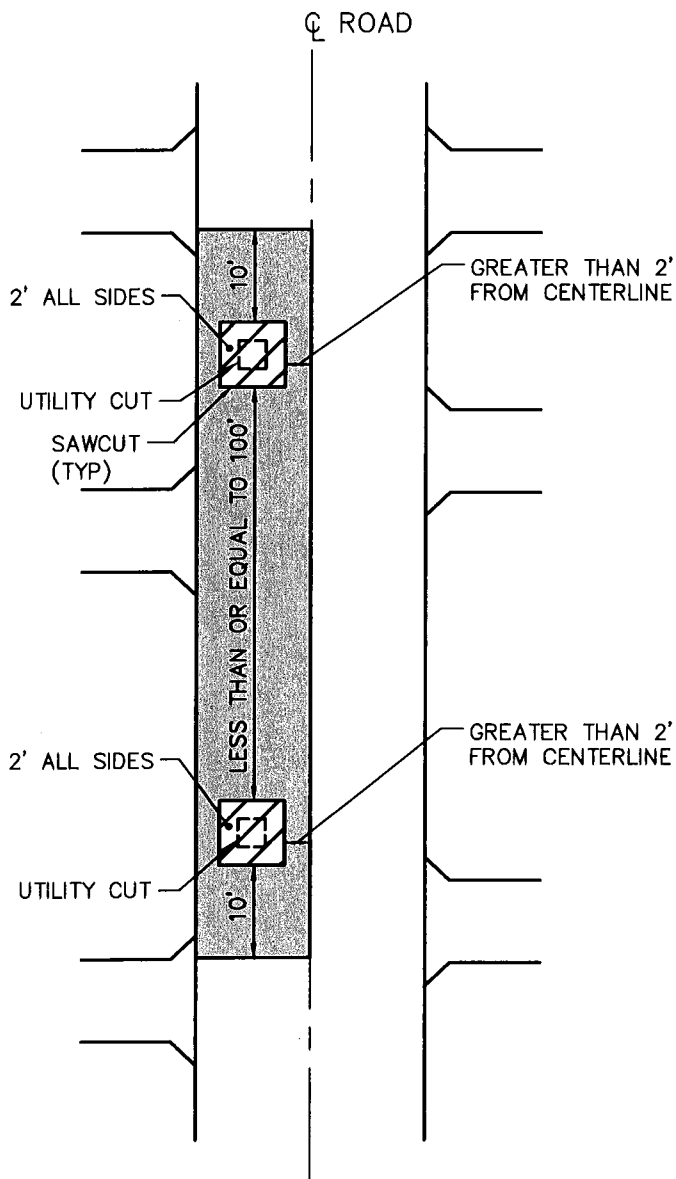
1 OF 1



-  INDICATES LIMITS OF 2" MILL AND ASPHALT RESURFACE
-  PROPOSED PAVEMENT CUT

- NOTE:
1. THIS DETAIL REQUIRES THAT THE FULL WIDTH OF A LANE BE MILLED AND PAVED IF WORK OCCURS WITHIN THAT LANE.
  2. THIS DETAIL SHALL APPLY ON ALL CITY STREETS, INCLUDING THOSE WITH MULTIPLE LANES.

FOR USE WITH TYPICAL  
DETAIL NO. 6 AND 7

PROJNO DATE  
16005 5-18-16

**City of Edgewood**  
**Encroachment Permit Standard Details**  
Typical Detail No. 9  
Pavement Restoration Limits  
(Several Pavement Cuts On One Street)



**BRANDSTETTER  
CARROLL INC**  
ARCHITECTS-ENGINEERS-PLANNERS  
308 East 8th Street, Cincinnati, OH 45202  
p. 513.651.4224 www.brandstettercarroll.com

SHEET

1 OF 1

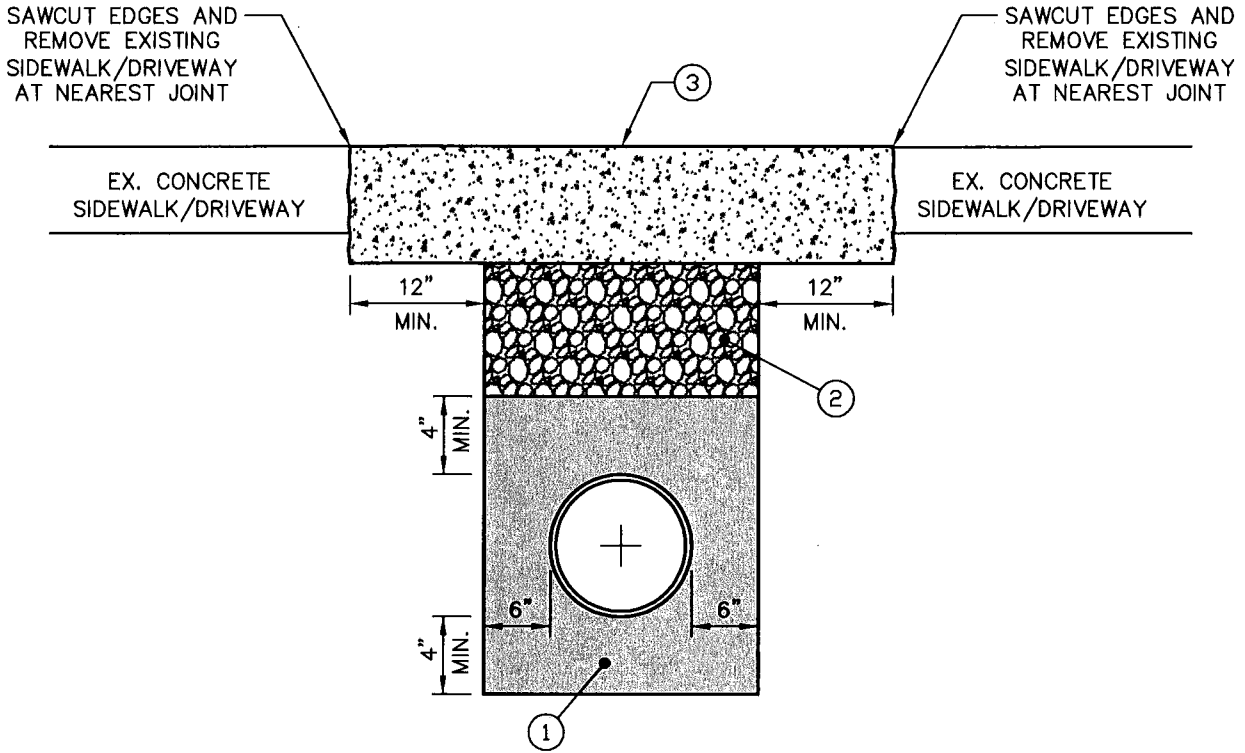

- ① PIPE BEDDING
- A. COMPACT SAND IN TRENCH IN LAYERS 6" OR LESS TO WIDTH AND ELEVATION SHOWN.
  - B. EXCAVATE A GROOVE IN COMPACTED SAND TO CONFORM TO PIPE SHAPE WITH APPROX. 4" OF SAND BELOW BOTTOM OF PIPE.
  - C. INSTALL PIPE AT CORRECT ALIGNMENT AND ELEVATION RECOMPACT ANY LOOSE SAND DISTURBED DURING INSTALLATION.
- ② BACKFILL
- A. UNDER CONCRETE SIDEWALK OR DRIVEWAY
    1. #57 AGGREGATE BACK FILL COMPACTED IN LAYERS OF 6" OR LESS TO PAVEMENT SUBGRADE, COMPACT TO 80% RELATIVE DENSITY (ASTM D4253, D4254)
- ③ SIDEWALK AND DRIVEWAY RESTORATION
- A. SIDEWALK
    1. KTC 605 - 4" CONCRETE SIDEWALK
  - B. CONCRETE DRIVEWAY
    1. KTC 505 - 6" CONCRETE DRIVEWAY

NOTE:  
CONCRETE FOR DRIVEWAYS AND SIDEWALKS SHALL BE KTC 601 CLASS AA STRENGTH MIX SPECIFICATIONS, F=4000 PSI 28 DAY COMPRESSIVE STRENGTH.

X:\2016 Projects\16005 Edgewood Eng\Encroachment Permit Drawings\DETAILS.dwg, 6/15/2016 10:43:17 AM, Bluebeam PDF10 Printer HighRes.pc3

PROJNO DATE  
16005 5-18-16

**City of Edgewood  
Encroachment Permit Standard Details**

Typical Detail No. 10  
driveway And Sidewalk Replacement



**BRANDSTETTER  
CARROLL INC**  
ARCHITECTS-ENGINEERS-PLANNERS  
308 East 8th Street, Cincinnati, OH 45202  
p. 513.651.4224 www.brandstettercarroll.com

SHEET

1 OF 1

X:\\_2016 Projects\16005 Edgewood Eng\Encroachment Permit Drawings\DETAILS.dwg, 6/15/2016 10:43:18 AM, Bluebeam PDFIO Printer HighRes.pc3

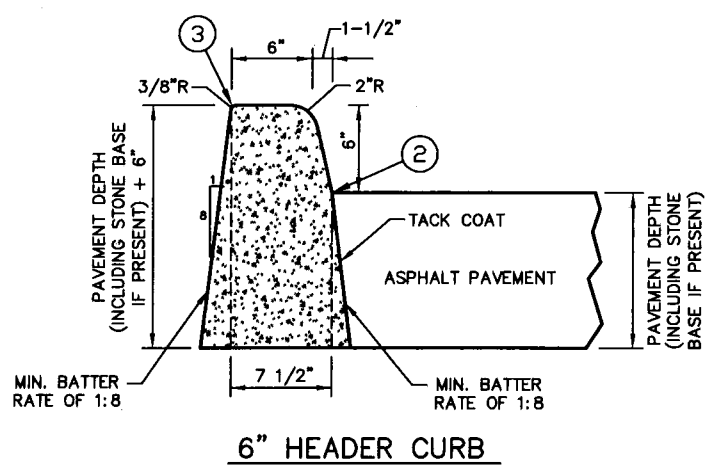
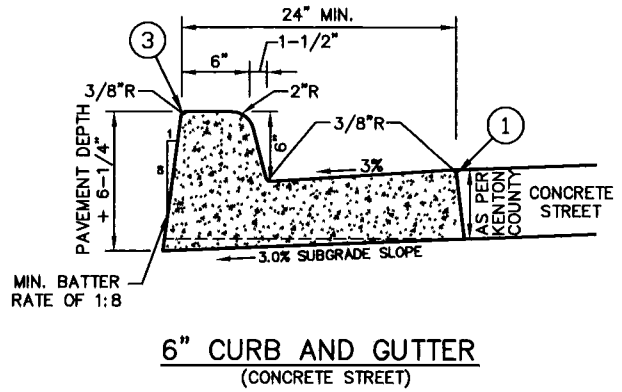
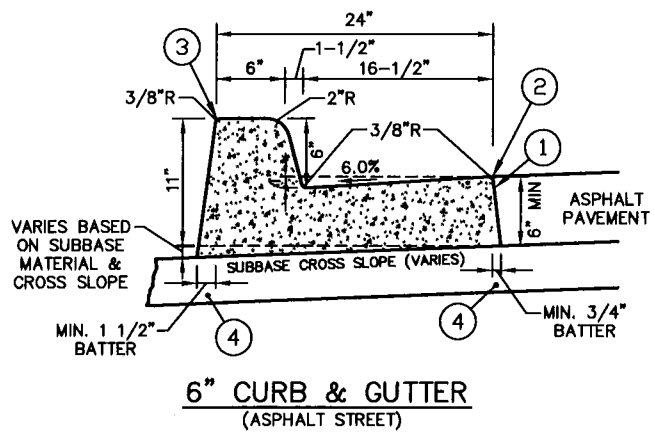

- NOTE:
1. THE TYPICAL CURBS SHOWN ARE FOR NEW CONSTRUCTION. WHEN REPLACING EXISTING CURBS, THE SIZE AND SHAPE SHOULD MATCH THE CURB THAT WAS REMOVED.
  2. CONTRACTOR SHALL FILL BEHIND CURB TO THE TOP OF CURB WITH TOPSOIL AND RESTORE YARD WITH SEED AND MULCH.
  3. CONCRETE FOR CURBS SHALL BE KTC 601 CLASS AA STRENGTH MIX SPECIFICATION, F=4000 PSI 28 DAY COMPRESSIVE STRENGTH.
  4. WHEN THE PAVEMENT IS SLOPING AWAY FROM THE CURB (FOR EXAMPLE, AROUND ISLANDS OR ADJACENT TO SUPER ELEVATED PAVEMENT SECTIONS), THE SLOPE IN THE GUTTER SHALL BE REVISED TO MATCH THE SLOPE OF THE PAVEMENT

- LEGEND:
- ① SAWCUT AND REMOVE EXISTING CURB (CONCRETE CURB REPLACEMENT SHALL GO FROM NEAREST JOINT TO NEAREST JOINT)
  - ② APPLY HOT ASPHALT SEALER WHERE ASPHALT MEETS CURB (BY OTHERS)
  - ③ TOP OF REPLACEMENT CURB TO MATCH LINE AND GRADE OF EXISTING CURB
  - ④ MAINTAIN SAME BATTER RATE FOR CURB THICKNESSES GREATER THAN 6" BATTER SHOWN ON THESE DETAILS ARE THE MIN. FOR MACHINE FORMER CURBS. HAND FORMED AND PLACED CURBS DO NOT REQUIRE THE BATTER SHOWN

PROJNO DATE  
16005 5-18-16

**City of Edgewood**  
**Encroachment Permit Standard Details**  
**Typical Detail No. 11**  
**Typical Concrete Curb Replacement**



**BRANDSTETTER**  
**CARROLL INC**  
ARCHITECTS-ENGINEERS-PLANNERS  
308 East 8th Street, Cincinnati, OH 45202  
p.513.651.4224 www.brandstettercarroll.com

SHEET  
**1 OF 1**

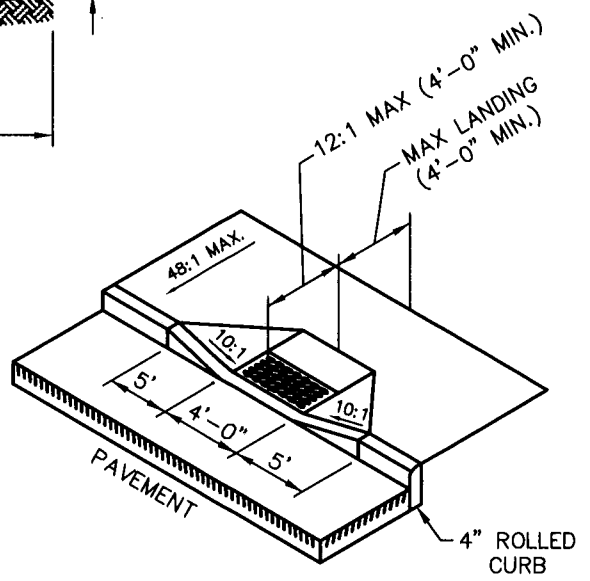
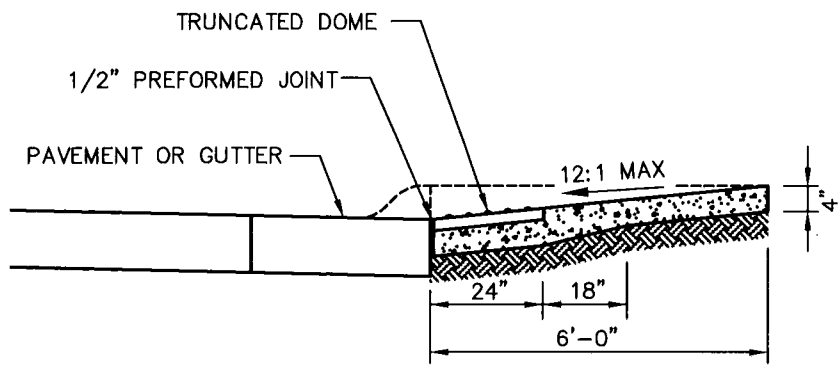

**PERPENDICULAR HANDICAP RAMP**

**NOTE:**

TRUNCATED DOMES: INSTALL DETECTABLE WARNINGS (TRUNCATED DOMES) FOR A DISTANCE OF 24" FROM THE BACK OF CURB FOR THE ENTIRE WIDTH OF THE RAMP OPENING.

PAVER TO MATCH ADJACENT FIELD PAVEMENT SURFACE.

PAVERS WILL MEET ASTM C 902 CLASS SX, TYPE 1 OR C 936, OR C1272 TYPE R.

**ACCEPTABLE MANUFACTURES AND PRODUCTS:**

- WHITACRE-GREER FIREPROOFING COMPANY  
1400 S. MAHONING AVE, ALLIANCE, OHIO 44601, (800) WG PAVER, ADA PAVER, 4"x8"x2 1/4", CLEAR RED (RUSTIC) #30, AND MULBERRY #34
- HANOVER ARCHITECTURAL PRODUCTS  
240 BENDER ROAD, HANOVER PA, 17331 (717) 837 -0500  
DETECTABLE WARNING PAVER, ACCESS TILE REPLACEABLE CAST IN PLACE 24X48  
ACC-R-2448 COLONIAL RED. PROVIDE SAMPLE FOR APPROVAL TO CITY REPRESENTATIVE.

X:\\_2016 Projects\16005 Edgewood Eng\Encroachment Permit Drawings\DETAILS.dwg, 6/15/2016 10:43:18 AM, Bluebeam PDFIO Printer-HighRes.pc3

PROJNO 16005	DATE 5-18-16
-----------------	-----------------

**City of Edgewood**  
**Encroachment Permit Standard Details**  
 Typical Detail No. 12  
 Typical Handicap Curb Ramp Section  
 With Truncated Dome Pavers



**BRANDSTETTER  
CARROLL INC**  
 ARCHITECTS-ENGINEERS-PLANNERS  
 308 East 8th Street, Cincinnati, OH 45202  
 p.513.651.4224 www.brandstettercarroll.com

SHEET <b>1 OF 1</b>
------------------------

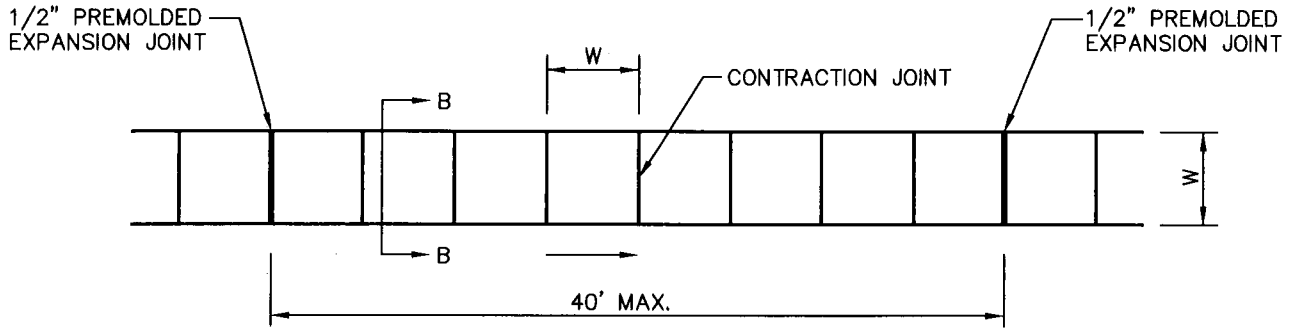

PLAN VIEW

W = MATCH EXISTING WIDTH

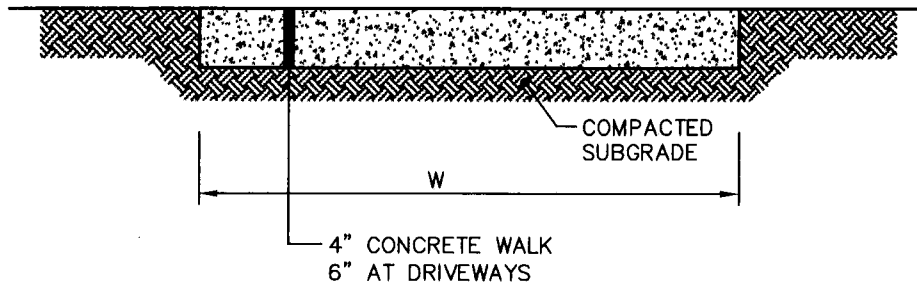

SECTION B-B

NOTE:  
 CONCRETE FOR DRIVES AND SIDEWALK SHALL BE KTC 601 CLASS AA STRENGTH  
 MIX SPECIFICATIONS, F = 4000 PSI 28 DAY COMPRESSIVE STRENGTH.

X:\2016 Projects\16005 Edgewood Eng\Encroachment Permit Drawings\DETAILS.dwg, 6/15/2016 10:43:19 AM, Bluebeam PDF10 Printer HighRes.pc3

PROJNO DATE  
 16005 5-18-16

**City of Edgewood  
 Encroachment Permit Standard Details**

Typical Detail No. 13  
 Concrete Sidewalk Detail



**BRANDSTETTER  
 CARROLL INC**  
 ARCHITECTS • ENGINEERS • PLANNERS  
 308 East 8th Street, Cincinnati, OH 45202  
 p. 513.651.4224 www.brandstettercarroll.com

SHEET

1 OF 1



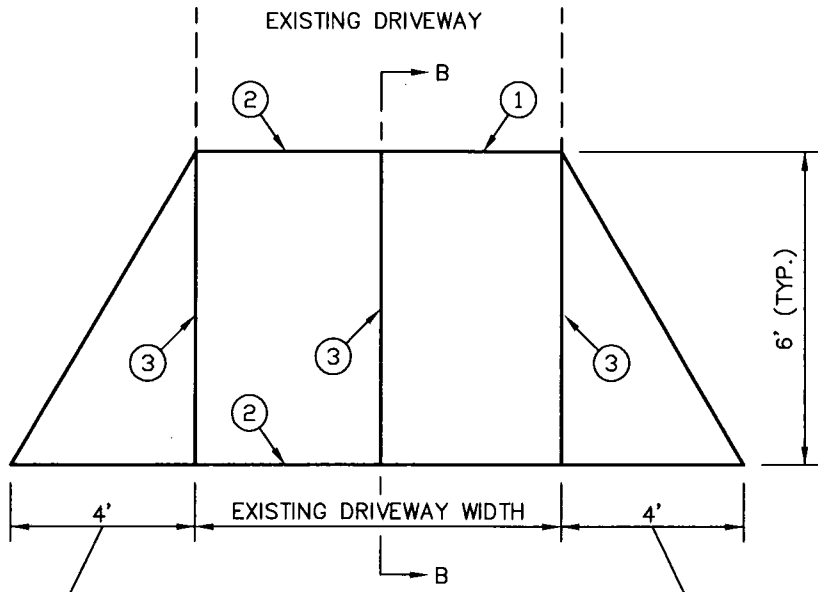

NOTE: EXCEPT WHEN NECESSARY TO AVOID POLE OR AS DIRECTED BY THE ENGINEER

**PLAN VIEW**

NOTE: EXCEPT WHEN NECESSARY TO AVOID POLE OR AS DIRECTED BY THE ENGINEER

NOTE: ANY YARD AREA DISTURBED BY THE CONSTRUCTION OF THE DRIVEWAY APRON SHALL BE RESTORED WITH TOPSOIL, SEED AND MULCH. (INCIDENTAL TO DRIVEWAY REPLACEMENT)

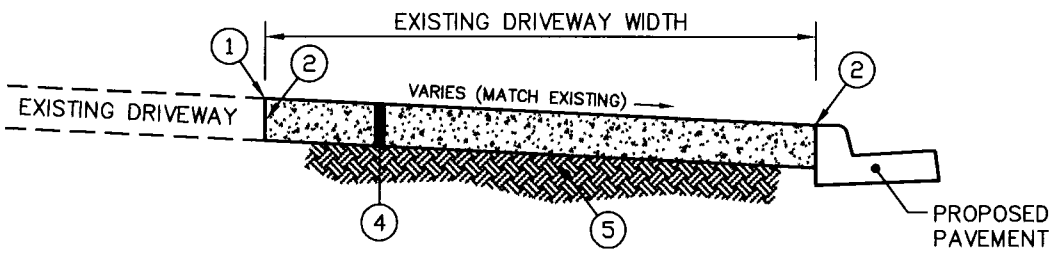

**SECTION B-B**

**LEGEND:**

- ① SAWCUT AND REMOVE EXISTING CONCRETE PAVEMENT
- ② 1/2" PREFORMED EXPANSION JOINT MATERIAL
- ③ TOOLED JOINT
- ④ KTC ITEM 505 - 6" CONCRETE DRIVEWAY/APRON
- ⑤ KTC ITEM 207 - SUBGRADE RESHAPING & COMPACTING

X:\2016 Projects\16005 Edgewood Eng\Encroachment Permit Drawings\DETAILS.dwg, 6/15/2016 10:43:20 AM, Bluebeam PDF10 Printer HighRes.pcl

PROJNO DATE  
16005 5-18-16

**City of Edgewood**  
**Encroachment Permit Standard Details**  
 Typical Detail No. 14  
**Concrete Driveway**  
**Apron Replacement Detail**



**BRANDSTETTER  
 CARROLL INC**  
 ARCHITECTS-ENGINEERS-PLANNERS  
 308 East 8th Street, Cincinnati, OH 45202  
 p. 513.651.4224 www.brandstettercarroll.com

SHEET

1 OF 1

X:\2016 Projects\16005 Edgewood Eng\Encroachment Permit Drawings\DETAILS.dwg, 6/15/2016 10:43:21 AM, Bluebeam PDF10 Printer HighRes.pc3

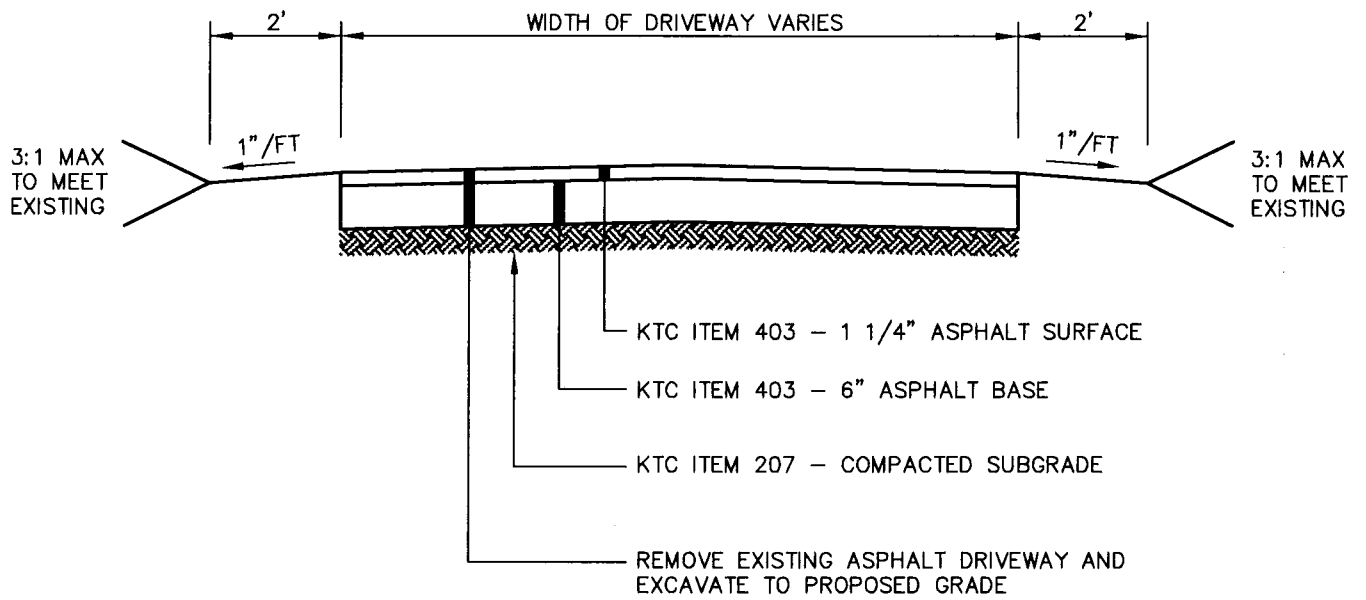

PROJNO DATE  
16005 5-18-16

City of Edgewood  
Encroachment Permit Standard Details

Typical Detail No. 15  
Asphalt Driveway Replacement



BRANDSTETTER  
CARROLL INC  
ARCHITECTS-ENGINEERS-PLANNERS  
308 East 8th Street, Cincinnati, OH 45202  
p. 513.651.4224 www.brandstettercarroll.com

SHEET

1 OF 1

**ORDINANCE 2016-07-08**

**AN ORDINANCE OF THE CITY OF EDGEWOOD IN KENTON COUNTY, KENTUCKY, PROHIBITING THE REMOVAL OR EXCAVATION OF ANY PAVEMENT, SURFACE OR SUB-SURFACE ROCKS OR SOIL OR ANY OTHER MATERIAL FROM ANY PUBLIC WAY IN THE CITY OF EDGEWOOD WITHOUT OR CONTRARY TO A PUBLIC WAY EXCAVATION PERMIT FROM THE CITY OF EDGEWOOD FOR THAT REMOVAL OR EXCAVATION.**

**WHEREAS**, the unregulated removal and excavation of the pavement, surface and sub-surface rocks and soils and other material from the streets and other public ways in the City of Edgewood result many times in inconsistent and inferior restoration, all of which is adverse to the public health, safety, convenience and welfare;

**NOW, THEREFORE, BE IT ORDAINED** by the City of Edgewood, in Kenton County, Kentucky, as follows:

**Section 1.0 – Definitions**

As used herein, the following words and phrases have the meanings provided for them:

- 1.1 – **person**            The word “person”, means any human being and every combination thereof in the form of a corporation, partnership, limited liability company unincorporated association or otherwise, including, without limitation, public utilities.
  
- 1.2 – **nobody**            The word “nobody” means no person.
  
- 1.3 – **everybody**        The word “everybody means every person
  
- 1.4 – **public way**        The words “public way”, mean a street, road, avenue, highway and every other parcel of real estate to which the public has a right of passage, except those that are subject to the exclusive regulation of Kenton County or the Commonwealth of Kentucky.
  
- 1.5 – **restoration**        The word “restoration” means the replacement of pavement, surface and subsurface rocks and soil and any other material removed or excavated from any public way in the City of Edgewood.

## 1.6 – Edgewood Street Excavation Standards

The words “Edgewood Street Excavation Standards” mean the standards for the removal or excavation of pavement, surface and subsurface rocks and soil and any other material from the public ways in the City of Edgewood and the replacement thereof attached hereto and incorporated herein by reference.

## Section 2.0 – Edgewood Street Excavation Standards

The Edgewood Street Excavation Standards are hereby approved and adopted as the standards of the City of Edgewood for the removal or excavation of pavement, surface and subsurface rocks and soils and other materials from the public ways in the City of Edgewood and the restoration thereof

## Section 3.0 – Prohibitions

Nobody other than the City of Edgewood, and the employees and contractors thereof, shall, by either act or omission, cause, permit, promote, suffer, allow, aid, assist, encourage or engage in the removal or excavation of any pavement, surface or subsurface rocks and soil, or any other material from any public way in the City of Edgewood without or contrary to a Public Way Excavation Permit from the City of Edgewood for that removal, excavation and restoration.

## Section 3.0 – Permits

### 3.1 Excavation Permits

A Public Way Excavation Permit may be issued by the City of Edgewood through the Edgewood City Administrator to anyone who makes application therefor; but only upon:

3.1.1 The receipt by the Edgewood City Clerk of the following documents:

3.1.1.1 A completed application for a Public Way Excavation Permit on a form provided by the City, which shall include, without limitation, all of the following information and documentation:

- (a) The name, address, telephone number and e-mail address of the applicant.

- (b) An identification of the public way in which the excavation is proposed, by name and location.
- (c) The area of that public way for which the removal or excavation is proposed
- (d) A description of the proposed removal or excavation and restoration in conformity with the Edgewood Street Excavation Standards, including, without limitation:
  - (i) The purpose of the excavation.
  - (ii) The size, area and location of the excavation.
  - (iii) The excavation barricades.
  - (iv) The duration of the excavation.
  - (v) The restoration of the excavation in conformity with the Edgewood Street Excavation Standards, with an estimate of the time and cost thereof in conformity with the R.S. Means Construction Cost Data, latest edition.
- (e) A schedule of the owners of each parcel of real estate abutting upon each side of that portion of the public way for which the excavation is proposed for the entire length thereof, including the names and mailing addresses of the owners thereof, according to the records of the Kenton County Property Valuation Administrator.
- (f) A guaranty of the restoration of the pavement, surface and sub surface rocks and soils and any other material removed from the public way in the manner and time described in the application, with a daily penalty of \$100 for delayed performance through a deposit of cash, bank check or an unconditional irrevocable letter of credit approved by and payable to the City of Edgewood, in an amount equal to the cost of the restoration identified in the application plus 25% thereof.

- (g) An agreement of any applicant (Governmental agencies prohibited by State law are exempt from this requirement) to defend, pay, indemnify and hold the City and the officers, agents, employees and volunteers thereof, harmless from each, every, any and all claims for losses, expenses, costs, compensation, and other damages of every kind and nature, and the defense thereof, including costs and attorney fees, and all claims, demands and causes of action for them, both at law and in equity, including, without limitation, third party actions and actions for contribution and/or indemnification, which are in any way related to the proposed removal, excavation and restoration
  
- (h) The following policies of insurance through companies approved by the City in which the Applicant is the named insured and the coverage of the Applicant is primary and non-contributory.
  - (i) Workmen's Compensation Insurance, specific to the State of Kentucky, as required by the terms of Chapter 342 of the Kentucky Revised Statutes.
  
  - (ii) A General Liability Policy of Insurance, ISO form CGL 00011001 or an equivalent approved by the City, by which the insurance company agrees to pay all damages resulting from any action or omission of the Applicant or the City that is in any way related to the proposed excavation and restoration with limits of no less than One Million (\$1,000,000.00) Dollars per occurrence, with the City of Edgewood named as an "Additional Insured." The additional insured endorsements must be CG20101185 or a combination of CG20100704 and CG20370704 or an equivalent approved by the City. The general liability policy shall be endorsed to provide the aggregate limit on a "per project" basis.
  
  - (iii) Automobile Liability Insurance, including non-owned liability, with limits of no less than One Million (\$1,000,000.00) Dollars combined single limit.

- (iv) Installation coverage for materials at risk on the site of the Work of the Contractor, in an amount sufficient to cover the replacement of those materials and equipment at risk at that site.
- (i) A non-refundable application fee of \$100.00 for the first application in a calendar year and \$15 for each additional application in that same calendar year, which may be paid with each application or quarterly in advance

3.1.2 A determination by the Edgewood Public Services Director that the removal or excavation of pavement, surface and sub-surface rocks and soil and other materials from the public ways in the City of Edgewood and the restoration thereof proposed in the application is in conformity with the Edgewood Street Excavation Standards

## **Section 4.0 – Restoration**

### **4.1 Inspection**

At least 2 days before restoration is commenced, the City shall be notified thereof and the Edgewood General Services Director shall cause the materials to be used therein and the method thereof to be inspected for conformance with the Edgewood Street Excavation Standards

### **4.2 Deficiencies**

In the event that the Edgewood General Services Director has any reason to believe that the restoration is not in conformity with the standards and regulations of the Edgewood Street Excavation Standards, the General Services Director shall provide the Applicant with a written notice thereof specifically identifying the deficiencies in the restoration with a date not less than ten (10) days thereafter by which those deficiencies must be remedied. The Applicant may appeal the decision of the General Services Director to the Edgewood City Administrator by a written request for a due process hearing delivered to the City Clerk within 7 days after the notice of the non-conformance; but, In the event that the Applicant fails to appeal the decision of the Edgewood General Services Director or that decision is sustained by the Edgewood City Administrator and the Applicant fails to remedy the deficiencies within the time allowed, the Edgewood General Services Director shall provide the Applicant with a written notice that in the event the identified deficiencies are not remedied within a specific period of

time thereafter, the City of Edgewood shall cause the deficiencies to be remedied through employees thereof or an independent contractor, at the cost of the Applicant through the forfeiture of the cash, bank check or unconditional irrevocable letter of credit provided with the application for the Excavation Permit.

### **Section 5.0 – Enforcement**

The provisions of this ordinance may be enforced through either or both criminal prosecutions and civil prosecutions pursuant to the provisions of the Local Government Code Enforcement Board Act at K.R.S. 65.8801 through K.R.S. 65.8839, and all other legal remedies, both at law and in equity.

### **Section 6.0 Violations**

A violation of this ordinance occurs whenever anybody, by either act or omission, conspires causes, permits, encourages, aids, assists, allows or engages in any of the acts, actions, behavior, conditions and occurrences prohibited by this ordinance; and each and every separate non-continuing occurrence thereof, and each and every day of each continuing occurrence thereof is a separate violation of this ordinance.

### **Section 7.0 Civil Offense**

Each separate violation of this ordinance is hereby classified as a civil offense; and, pursuant to the authority of K.R.S. 82.710, the penalties to be imposed upon persons determined to have violated this ordinance are hereby established as follows:

7.1 The maximum civil fine that may be imposed for each separate violation of this ordinance is hereby established at \$500.00 for a first violation, \$750 for a second occurrence of the same violation, and \$1,000 for the third and each subsequent occurrence of the same violation plus the costs of collection, including, without limitation, court costs and attorney fees.

7.2 The specific civil fine that shall be imposed for each separate violation of this ordinance in the event that a citation for that violation is not contested is hereby established at \$100.00 for a first violation, \$250.00 for a second occurrence of the same violation, and \$500.00 for the third and each subsequent occurrence of the same violation, plus the costs of collection, including, without limitation, court costs and attorney fees.

### **Section 8.0 Criminal Offense**

Each violation of this ordinance shall be a misdemeanor for which everybody convicted thereof in a court of competent jurisdiction shall be



sentenced to pay a criminal fine not to exceed the maximum amount of \$500.00 as provided in K.R.S. 534.050 (2) (a) or a term of imprisonment not to exceed the maximum period of twelve (12) months as set forth in K.R.S. 532.090 (1), or both.

**Section 9.0 Provisions Severable**

The provisions of this ordinance are severable; and the invalidity of any provision of this ordinance shall not affect the validity of any other provision thereof; and such other provisions shall remain in full force and effect as long as they remain valid in the absence of those provisions determined to be invalid.

**Section 10.0 Conflicting Ordinances Repealed**

All ordinances or parts of ordinances in conflict with the provisions of this ordinance are hereby repealed

**Section 11.0 Effective Date**

This ordinance shall be effective as soon as possible according to law.

**Section 12.0 Publication**

This ordinance shall be published in summary pursuant to K.R.S. 83A.060 (9).

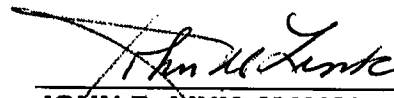
  
\_\_\_\_\_  
JOHN D. LINK, MAYOR

ATTEST:

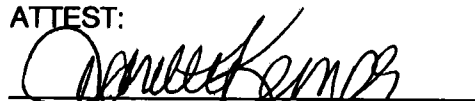
  
\_\_\_\_\_  
JEANNETTE KEMPER, CITY CLERK  
FIRST READING: 8/15/16  
SECOND READING: 9/19/16  
PUBLISHED: 9/23/16